



durashine[®]

TATA BLUESCOPE STEEL

COLORing lives in steel



DURASHINE[®] Liner

*Perfect Solution for
Interior Application*

DESIGN ADVANTAGES

- Lightest wall cladding for interior and exterior application*
- Slightly fluted panel gives attractive look
- Provides easy solution for false ceiling and wall partition
- Panels can be installed in horizontal and vertical direction

DURASHINE® Liner Profile

DURASHINE® Liner Profile is an attractive, slightly fluted wall & ceiling cladding for exterior and interior use on straight or curved surfaces.

DURASHINE® Liner Profile is manufactured out of high strength steel which has longitudinal flutes that provide rigidity and strength along the length of the sheet while retaining full flexibility across the width. It can be used with the flutes vertically

or horizontally, however, DURASHINE® Liner Profile is not intended as a roofing material.

It's elegant appearance makes it suitable for many applications where flat sheets would not normally be considered such as ceiling, partition facings, screens, garage doors, fascias and barge boards.



Corridor Wall Panel

Warehouse Interior Wall Panel & False Ceiling

Profile

DURASHINE® Liner is 1110 mm wide coverage profile with 3.5 mm deep rib at pitch of 50.5 mm centre to centre distance. (Refer figure 1)

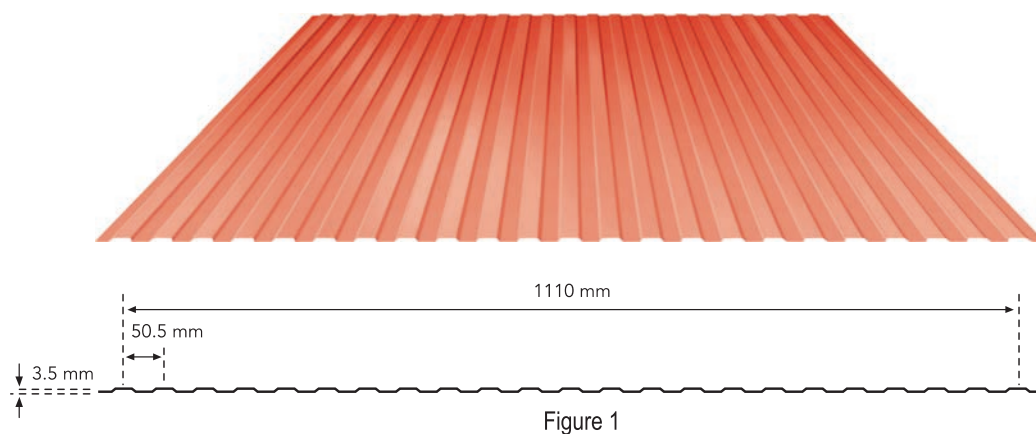

Figure 1

Installation

Panel Fixing Details

DURASHINE® Liner Profile can be attached to the frame with the flutes either vertical or horizontal. (Refer figure 2 and 3)

When fixing with flutes horizontally, ensure that the top sheet overlaps the sheet below. The end laps are necessary as they provide long runs and allow at least 75 mm lap on either side of the support.

Location of Fasteners

Fastener should be located either at the side lap or adjacent to it. For quality finish, fasteners at the end laps of DURASHINE® Liner Profile should be located at every 202 mm O.C.

At intermediate supports, four fasteners should be used equidistant across the sheet at 500 mm O.C. (Refer figure 2 and 3)

For internal applications not subject to wind loads, the number of fasteners may be reduced by 50%, except for ceiling applications.

Interior Application

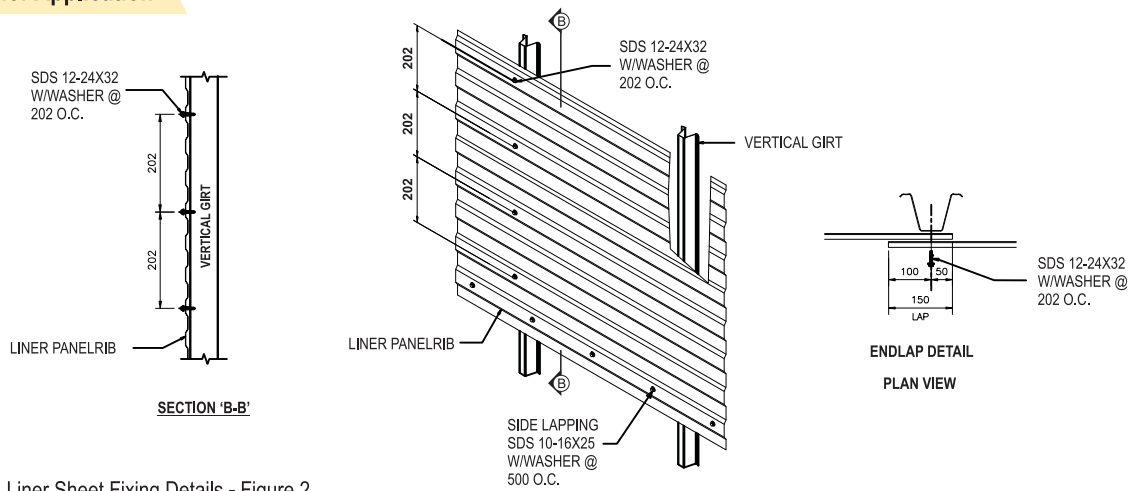

Horizontal Liner Sheet Fixing Details - Figure 2

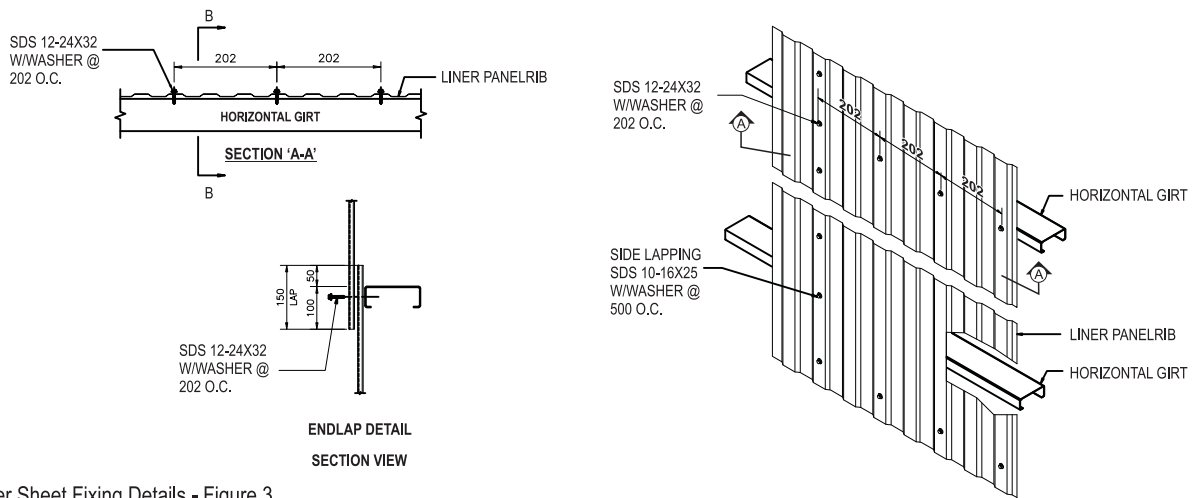

Vertical Liner Sheet Fixing Details - Figure 3

Side Lapping

Three types of side lapping methods are used: the overlapping flute, the butt joint and the edge lap joint. When using the overlapping or edge lap joint methods, side lap fasteners are required at 500 mm O.C. (Refer figure 4)

For sheets fixed on external applications where sealing is required, seal end laps with a suitable sealant.

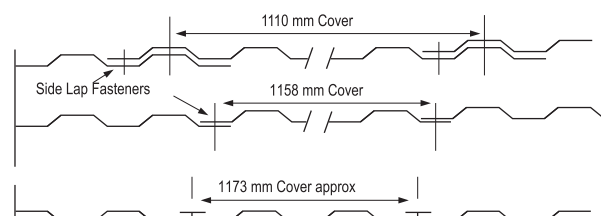
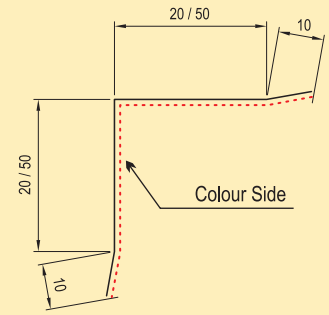

Figure 4

Liner Corner Flashing



Internal Flashing



External Flashing

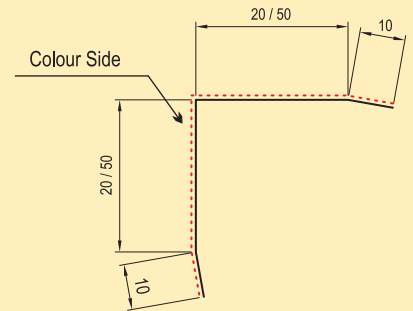

*All dimensions are in mm

Applications



Canteen Interior Wall Panel



Terrace False Ceiling



Bus Stop False Ceiling

Removal of Guard Film

Remove the guard film after installation. If not removed it could have adverse effect on the colour and will be broken into pieces due to weathering effects.



Colour Range



*Disclaimer: 1) The above colours are only for illustrative purpose and actual colours may vary.
2) All the above colour names are trademarks under DURASHINE™ brand.



Maintenance Recommendation: Clean and maintain your roof regularly to remove dust and dirt.